



冷压针及对应工具 / Crimp contacts pin and Tools

冷压接插针 Crimp contacts

10A 冷压针

表1

技术参数/Technical data

材料: 铜

Material: copper

接触电阻/Contact resistance: $\leq 3m\Omega$

接线形式: 冷压工具压接

Terminal: crimp connection



(镀银)冷压接插针/Crimp contacts.silver-platea

标识 Identification	线规 Wire gauge	剥线长度 Stripping length	公插针 Male	订货号 Part Number	母插针 Female	订货号 Part Number	内孔直径
no groove	0.5 mm ²	AWG 20	8.0m m	CDM-0.5		CDF-0.5	1.15
1 groove	0.75 mm ²	AWG 18	8.0m m	CDM-0.75		CDF-0.75	1.3
1 groove	1.0 mm ²	AWG 18	8.0m m	CDM-1.0		CDF-1.0	1.45
2 groove	1.5 mm ²	AWG 16	8.0m m	CDM-1.5		CDF-1.5	1.75
3 groove	2.5 mm ²	AWG 14	8.0m m	CDM-2.5		CDF-2.5	2.25

(镀金)冷压接插针/Crimp contacts.Gold-plated

标识 Identification	线规 Wire gauge	剥线长度 Stripping length	公插针 Male	订货号 Part Number	母插针 Female	订货号 Part Number	内孔直径
no groove	0.5 mm ²	AWG 20	8.0m m	DDM-0.5		DDF-0.5	1.15
1 groove	0.75 mm ²	AWG 18	8.0m m	DDM-0.75		DDF-0.75	1.3
1 groove	1.0 mm ²	AWG 18	8.0m m	DDM-1.0		DDF-1.0	1.45
2 groove	1.5 mm ²	AWG 16	8.0m m	DDM-1.5		DDF-1.5	1.75
3 groove	2.5 mm ²	AWG 14	8.0m m	DDM-2.5		DDF-2.5	2.25

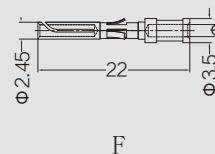
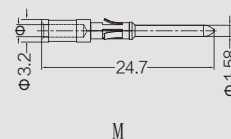

工具 Tools

冷压钳 Manual hydraulic clamp



退针器 Removal tool



压接线径 Wire gauge	型号/Type	订货号/Part Number
0.5-4mm ²	CRIMPBOX-0.5/4	

适用类型 For	型号/Type	订货号/Part Number
10A 冷压针 Crimp contacts	REMOV-GD	

冷压接插针 Crimp contacts

16A 冷压针

表2

技术参数/Technical data

材料: 铜

Material: copper

接触电阻/Contact resistance: $\leq 1m\Omega$

接线形式: 冷压工具压接

Terminal: crimp connection



(镀银)冷压接插针/Crimp contacts.silver-platea

标识 Identification	线规 Wire gauge	剥线长度 Stripping length	公插针 Male	订货号 Part Number	母插针 Female	订货号 Part Number	内孔直径
no groove	0.5 mm ²	AWG 20	7.5m m	CEM-0.5		CEF-0.5	1.15
1 groove	0.75 mm ²	AWG 18	7.5m m	CEM-0.75		CEF-0.75	1.3
1 groove	1.0 mm ²	AWG 18	7.5m m	CEM-1.0		CEF-1.0	1.45
2 groove	1.5 mm ²	AWG 16	7.5m m	CEM-1.5		CEF-1.5	1.75
3 groove	2.5 mm ²	AWG 14	7.5m m	CEM-2.5		CEF-2.5	2.25
wide groove	3.0 mm ²	AWG 12	7.5m m	CEM-3.0		CEF-3.0	2.55
no groove	4.0 mm ²	AWG 12	7.5m m	CEM-4.0		CEF-4.0	2.85

(镀金)冷压接插针/Crimp contacts.Gold-plated

标识 Identification	线规 Wire gauge	剥线长度 Stripping length	公插针 Male	订货号 Part Number	母插针 Female	订货号 Part Number	内孔直径
no groove	0.5 mm ²	AWG 20	7.5m m	DEM-0.5		DEF-0.5	1.15
1 groove	0.75 mm ²	AWG 18	7.5m m	DEM-0.75		DEF-0.75	1.3
1 groove	1.0 mm ²	AWG 18	7.5m m	DEM-1.0		DEF-1.0	1.45
2 groove	1.5 mm ²	AWG 16	7.5m m	DEM-1.5		DEF-1.5	1.75
3 groove	2.5 mm ²	AWG 14	7.5m m	DEM-2.5		DEF-2.5	2.25
wide groove	3.0 mm ²	AWG 12	7.5m m	DEM-3.0		DEF-3.0	2.55
no groove	4.0 mm ²	AWG 12	7.5m m	DEM-4.0		DEF-4.0	2.85

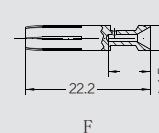
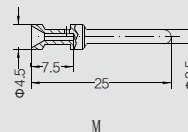

工具 Tools

冷压钳 Manual hydraulic clamp



退针器 Removal tool



压接线径 Wire gauge	型号/Type	订货号/Part Number
0.5-4mm ²	CRIMPBOX-0.5/4	

适用类型 For	型号/Type	订货号/Part Number
16A 冷压针 Crimp contacts	REMOV-GEE	

冷压针及对应工具 / Crimp contacts pin and Tools



冷压接插针 Crimp contacts

40A 冷压针

表3

技术参数/Technical data

材料: 铜

Material: copper

接触电阻/Contact resistance: $\leq 3m\Omega$

接线形式: 冷压工具压接

Terminal: crimp connection

(镀银)冷压接插针/Crimp contacts.silver-plated

标识 Identification	线规 Wire gauge	剥线长度 Stripping length	公插针 Male	订货号 Part Number	母插针 Female	订货号 Part Number	内孔直径
no groove	1.5 mm ²	AWG 16	9.0m m	CCM-1.5	CCF-1.5		1.75
1 groove	2.5 mm ²	AWG 14	9.0m m	CCM-2.5	CCF-2.5		2.25
1 groove	4.0 mm ²	AWG 12	9.6m m	CCM-4.0	CCF-4.0		2.85
2 groove	6.0 mm ²	AWG 10	9.6m m	CCM-6.0	CCF-6.0		3.5
3 groove	10 mm ²	AWG 8	15m m	CCM-10.0	CCF-10.0		4.3

(镀金)冷压接插针/Crimp contacts.Gold-plated

标识 Identification	线规 Wire gauge	剥线长度 Stripping length	公插针 Male	订货号 Part Number	母插针 Female	订货号 Part Number	内孔直径
no groove	1.5 mm ²	AWG 16	9.0m m	DCM-1.5	DCF-1.5		1.75
1 groove	2.5 mm ²	AWG 14	9.0m m	DCM-2.5	DCF-2.5		2.25
1 groove	4.0 mm ²	AWG 12	9.6m m	DCM-4.0	DCF-4.0		2.85
2 groove	6.0 mm ²	AWG 10	9.6m m	DCM-6.0	DCF-6.0		3.5
3 groove	10 mm ²	AWG 8	15m m	DCM-10.0	DCF-10.0		4.3

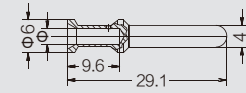

M

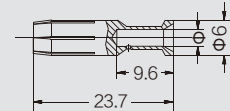

F

工具 Tools

冷压钳 Manual hydraulic clamp



压接线径 Wire gauge	型号/Type	订货号/Part Number
1.5-6mm ²	CRIMPBOX-1.5/6	
4-10mm ²	CRIMPBOX-4/10	

退针器 Removal tool



适用类型 For	型号/Type	订货号/Part Number
40A 冷压针 Crimp contacts	REMOV-GMK/40	

冷压接插针 Crimp contacts

70A 冷压针

表4

技术参数/Technical data

材料: 铜

Material: copper

接触电阻/Contact resistance: $\leq 1m\Omega$

接线形式: 冷压工具压接

Terminal: crimp connection

(镀银)冷压接插针/Crimp contacts.silver-plated

标识 Identification	线规 Wire gauge	剥线长度 Stripping length	公插针 Male	订货号 Part Number	母插针 Female	订货号 Part Number	内孔直径
no groove	10 mm ²	AWG 20	15.5m m	GKSM70-10	GKSF70-10		4.3
1 groove	16 mm ²	AWG 18	15.5m m	GKSM70-16	GKSF70-16		5.5
1 groove	25 mm ²	AWG 18	15.5m m	GKSM70-25	GKSF70-25		7.0

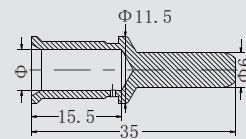

M

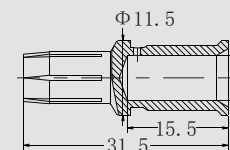

F

工具 Tools

液压钳 Manual hydraulic clamp



压接线径 Wire gauge	型号/Type	订货号/Part Number
10-240mm ²	CRIMPBOX-10/240	

冷压针及对应工具 / Crimp contacts pin and Tools



冷压接插针 Crimp contacts

100A 冷压针

表5

技术参数/Technical data

材料: 铜

Material: copper

接触电阻/Contact resistance: $\leq 3m\Omega$

接线形式: 冷压工具压接

Terminal: crimp connection

(镀银)冷压接插针/Crimp contacts.silver-platea

标识 Identification	线规 Wire gauge	剥线长度 Stripping length	公插针 Male	订货号 Part Number	母插针 Female	订货号 Part Number	内孔直径
no groove	10 mm ²	AWG	19m m	GKSM-10	GKSF-10		4.3
1 groove	16 mm ²	AWG	19m m	GKSM-16	GKSF-16		5.5
1 groove	25 mm ²	AWG	19m m	GKSM-25	GKSF-25		7.0
2 groove	35 mm ²	AWG	19m m	GKSM-35	GKSF-35		8.2

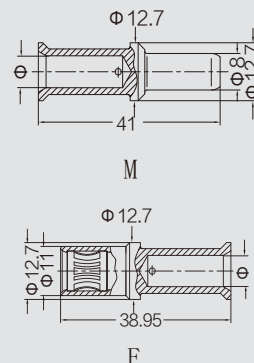

工具 Tools

冷压钳 Manual hydraulic clamp



压接线径 Wire gauge	型号/Type	订货号/Part Number
10-240mm ²	CRIMPBOX-10/240	

退针器 Removal tool



适用类型 For	型号/Type	订货号/Part Number
100A 冷压针 Crimp contacts	REMOV-GMK/G2MK	

冷压接插针 Crimp contacts

200A 冷压针

表6

技术参数/Technical data

材料: 铜

Material: copper

接触电阻/Contact resistance: $\leq 1m\Omega$

接线形式: 冷压工具压接

Terminal: crimp connection

(镀银)冷压接插针/Crimp contacts.silver-platea

标识 Identification	线规 Wire gauge	剥线长度 Stripping length	公插针 Male	订货号 Part Number	母插针 Female	订货号 Part Number	内孔直径
no groove	25 mm ²	AWG 20	7.5m m	GHSM200-25	GHSF200-25		7.0
1 groove	35 mm ²	AWG 18	7.5m m	GHSM200-35	GHSF200-35		8.2
1 groove	50 mm ²	AWG 18	7.5m m	GHSM200-50	GHSF200-50		10
2 groove	70 mm ²	AWG 16	7.5m m	GHSM200-70	GHSF200-70		11.5

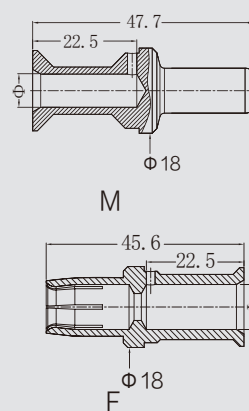

工具 Tools

液压钳 Manual hydraulic clamp



压接线径 Wire gauge	型号/Type	订货号/Part Number
10-240mm ²	CRIMPBOX-10/240	1234567890

编码销(导向销) / Coding pins



编码销(导向销) Coding pins

编码销/导向销(单个使用)



COD-PIN-M3

适用于可安装一个插芯或框架的外壳

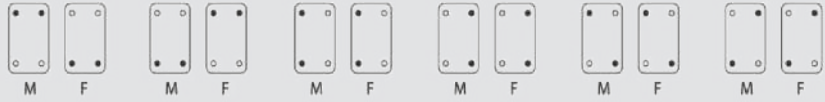

适用于可安装两个插芯或框架的外壳

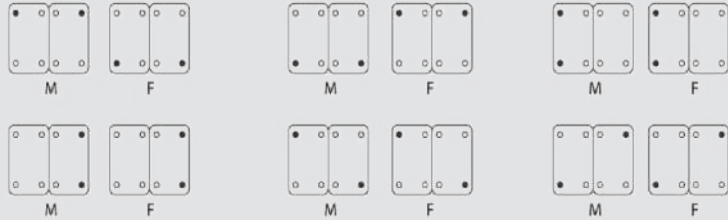

- 编码销 M-公插芯
- 正常螺丝 F-母插芯

编码销/导向销(带导向孔)



CODING-PIN-M3-F

适用于可安装一个插芯或框架的外壳

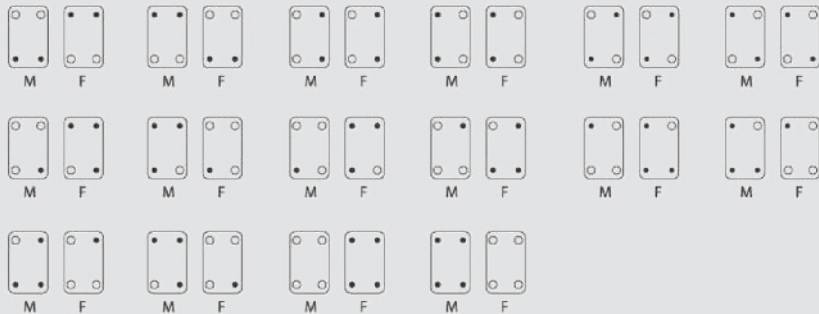

适用于可安装两个插芯或框架的外壳

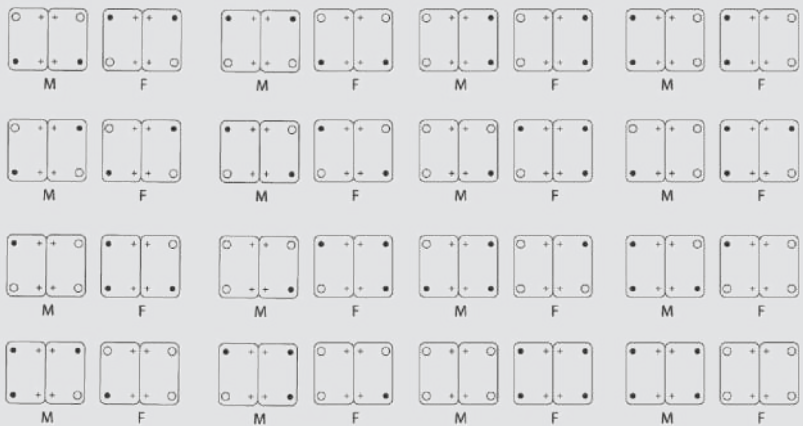

- 导向孔 M-公插芯
- 导向销 F-母插芯
- + 正常螺丝

使用此编码销，可避免相同连接器的误插。

编码Coding

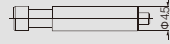
	型号/Type	订货号/Part Number	 <p>① 使用此编码销, 可避免相同连接器的误插 ② 适用于HEC, HEE, HE-5/0, HM-006, HM-008 ③ 使用编码销时, 公插对应孔不能装插针 ① Use of the coding pin prevents incorrect mating to other connectors of the same type. ② For HEC, HEE, HE-5/0, HM-006, HM-008 ③ The male pin should be omitted from the opposing cavity in the male insert.</p>
	COD-PIN-E		

编码销 Code pin

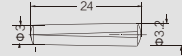
	型号/Type	订货号/Part Number	 <p>① 使用此编码销, 可避免相同连接器的误插 ② 适用于HD, HDD, HMD-012, HMDD-017, HQ-7/0, HQ-012/0 ③ 使用编码销时, 公插对应孔不能装插针 ① Use of the coding pin prevents incorrect mating to other connectors of the same type. ② For HD, HDD, HMD-012, HMDD-017, HQ-7/0, HQ-012/0 ③ The male pin should be omitted from the opposing cavity in the male insert.</p>
	COD-PIN-D		

滚花螺栓 Screw pin

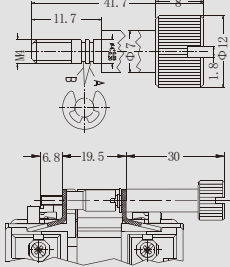
	型号/Type	订货号/Part Number	
	COD-PIN-M4		

套筒螺栓 Screw bash

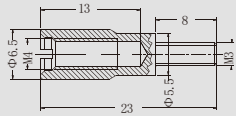
	型号/Type	订货号/Part Number	
	COD-PIN-T-M3		



固定框架/frame



安装架 Mounting

对接架 Docking frame



规格/Size	型号/Type	订货号/Part Number
6B	G6B-ADK	
10B	G10B-ADK	
16B	G16B-ADK	
24B	G24B-ADK	

技术参数 Technical characteristics

材料 Material

- 对接架 不锈钢
- Docking frame stainless steel
- 固定螺栓 铁, 镀锌
- Fixing screws steel, zinc-plated

插入容差 Pull-in-range

-x轴 x-axis $\pm 1.5\text{mm}$ -y轴 y-axis $\pm 1.5\text{mm}$ 拔插次数 ≥ 500

Mechanical working life

安装开口 Assembly cut put

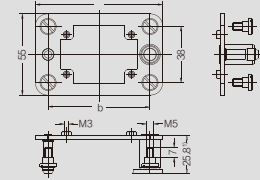

1)距离 电气针和光电缆距离最大27mm

气动针距离最大26.5mm

Distance for electrical and F.O. contacts max. 27 mm; for pneumatic contacts max. 26.5 mm

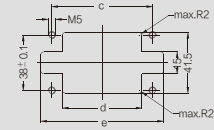

产品包括 Range of delivery:

1个架子 1 frame

4个带平头的螺栓, 用于固定对接架
4 cheese head shoulder screws
to fix the docking frame

规格Size	a	b	c	d	e
6B	86	69	69	54.5	84
10B	99	82	82	67.5	97
16B	119.5	102.5	102.5	88	117.5
24B	146	129	129	114.5	144

工具 Tools



退针器 Contact removal tools

D-sud 退针器 D-sub Contact removal tool



适用类型 For	型号/Type	订货号 /Part Number
5A 冷压针 Crimp contacts	REMOV-GMDS	

GD/GDD退针器 GD/GDD Contact removal tool



适用类型 For	型号/Type	订货号 /Part Number
10A 冷压针 Crimp contacts	REMOV-GD	

GEE 退针器 GEE Contact removal tool



适用类型 For	型号/Type	订货号 /Part Number
16A 冷压针 Crimp contacts	REMOV-GEE	

C型 退针器 Contact removal tool



适用类型 For	型号/Type	订货号 /Part Number
40A 冷压针 Crimp contacts	REMOV-GMK/40	

K型 退针器 Contact removal tool



适用类型 For	型号/Type	订货号 /Part Number
100A 冷压针 Crimp contacts	REMOV-GMK/G2MK	

送针器 Insertion Tool



适用类型 For	型号/Type	订货号 /Part Number
10A/16A辅助装针工具 Insertion tool for crimp contacts	REMOV-GD/GEE	

工具 Tools



压接工具tools

压线钳 Crimping tool



5A 冷压钳 5A Crimping tool

压接线径 Wire gauge	型号/Type	订货号 /Part Number
0.09-0.82mm ²	CRIMPBOX-0.09/0.82	

压线钳 Crimping tool



10A/16A/40A 冷压钳 10A/16A/40A Crimping tool

压接线径 Wire gauge	型号/Type	订货号 /Part Number
0.5-4mm ²	CRIMPBOX-0.5/4	
1.5-6mm ²	CRIMPBOX-1.5/6	
4-10mm ²	CRIMPBOX-4/10	

压线钳 Crimping tool



100A/650A 大电流手动液压钳 100A/650A manual hydraulic clamp

压接线径 Wire gauge	型号/Type	订货号 /Part Number
10-240mm ²	CRIMPBOX-10/240	

描述
Description

出力：自动泄压
Output: automatic
pressure release
出力：13T
Output: 13T
重量：6.2kg
Weight: 6.2kg

附件产品系列 Cable fittings and accessories



PG制螺纹与公制(M)螺纹对照表

Cross Reference from PG thread to Metric thread

由于产品描述中含有螺纹尺寸,采用公制螺纹可方便的理解电缆接头的规格尺寸
 以下是PG制螺纹与公制螺纹的对照表
 请注意采用公制的电缆接头,最大可夹紧的电缆直径可能会变小

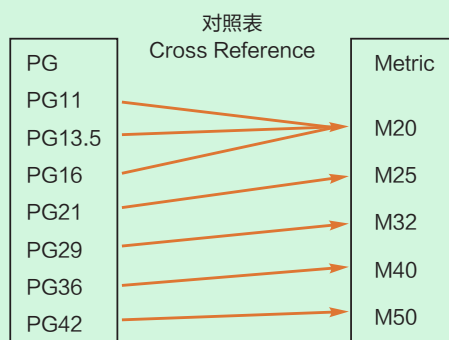

金属平口旋紧件,带多层密封圈,IP65 Cable sealing metal with multiple seal,IP65



材料: 黄铜镀镍
密封件: 丁腈橡胶
夹紧件: 尼龙塑料
工作温度: -40°C~+100°C
防护等级: IP68

Material: Nicked plated brass
Seal material: NBR
Press seal material: PA
Temperature range: -40°C~+100°C
Protection degree: IP68

规格	电缆直径 Øk mm	螺纹长度 GL mm	本体高度 H mm	扳手直径 mm	螺纹外径 AG mm	订货号 Part Number
PG 7	3-6.5	8	18	14	12.5	
PG 9	4-8	8.2	20	17	15.2	
PG 11	5-10	8.6	21	20	18.6	
PG 13.5	6.7-12	9	22	22	20.4	
PG16	10.2-14	10	23	24	22.5	
PG 21	13-18	10	25	30	28.3	
PG 29	18.5-25	12	30	40	37	
PG 36	23-32	14	35	50	47	
PG 42	32.7-38	14	38	57	54	
PG 48	37-44	16.6	40	64	59.3	
M12X1.5	3-6.5	8	18	14	12	
M16X1.5	4-8	8.2	20	17	16	
M20X1.5	6.7-12	9	22	22	20	
M25X1.5	13-18	10	25	30	25	
M32X1.5	18.5-25	12	30	40	32	
M40X1.5	23-32	14	35	50	40	
M50X1.5	32.7-38	14	38	57	50	
M63X1.5	37-44	16.6	40	64/68	63	

电缆端接头管接头D21(带橡胶保护套) Cable glands tube connectors(With rubber protective sleeve)



PG11	7-9	D21-11
PG13.5	9-13	D21-13.5
PG16	15-18	D21-16
PG21	18-21	D21-21
PG29	24-28	D21-29
PG36	32-36	D21-36
M16X1.5	5-7 7-9	D21-16M
M20X1.5	7-9 9-13	D21-20M
M24X1.5	9-13 13-15	D21-24M
M27X2	13-15 15-18	D21-27M
M30X2	15-18 18-21	D21-30M
M33X2	18-21 21-24	D21-33M
M36X2	21-24 24-28	D21-36M
M42X2	24-28 28-32	D21-42M

附件产品系列 / Cable fittings and accessories



塑料软管接头(配塑料波纹管)

Nylon flexible tube connectors

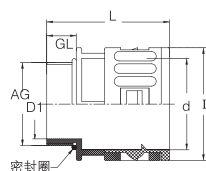

PG制 螺纹规格	配用软管 (d)	螺纹长度 (GL)	内孔 (D1)	外圆直径 (D)	高度 (H)	公制规格	英制规格	订货号 Part Number
PG 7	AD10	9.5	7.5	34.5	34.5	WNCP-PG7/AD10	WNCP-PG7/ 5/16"	
PG 9	AD13	9.5	11.5	34.5	34.5	WNCP-PG9/AD13	WNCP-PG9/ 3/8"	
PG 11	AD15.8	9.5	14	36	36	WNCP-PG11/AD15.8		
PG 13.5	AD18.5	11	16	39	39	WNCP-PG13.5/AD18.5		
PG 16	AD21.2	13	18	44	44	WNCP-PG16/AD21.2		
PG 21	AD28.5	13	23.5	47	47	WNCP-PG21/AD28.5		
PG 29	AD34.5	11.5	30.5	47	47	WNCP-PG29/AD34.5		
PG 36	AD42.5	13.5	40	52	52	WNCP-PG36/AD42.5		

M公制 螺纹规格	配用软管 (d)	螺纹长度 (GL)	内孔 (D1)	外圆直径 (D)	高度 (H)	公制规格	英制规格	订货号 Part Number
M12x1.5	AD10	10	8	17	34.5	WNCP-M12/AD10	WNCP-M12/ 5/16"	
M16x1.5	AD13	9.5	11.5	20	34.5	WNCP-M16/AD13	WNCP-M16/ 3/8"	
M18x1.5	AD15.8	9.5	14	23	36	WNCP-M18/AD15.8		
M20x1.5	AD18.5	11	16	26	39	WNCP-M20/AD18.5		
M20x1.5	AD21.2	13	15	29.5	44	WNCP-M20/AD21.2		
M25x1.5	AD21.2	13	18	29.5	44.5	WNCP-M25/AD21.2		
M25x1.5	AD28.5	13	20.5	37	47	WNCP-M25/AD28.5		
M32x1.5	AD28.5	13	24	37	47	WNCP-M32/AD28.5		
M40x1.5	AD34.5			51				
M40x1.5	AD42.5	13.5	33.5	63.5	52	WNCP-M40/AD42.5		
M50x1.5	AD54.5	13.5	42.5	63.5	53.5	WNCP-M50/AD54.5		
M63x1.5	AD54.5	14	55	43.5	53.5	WNCP-M63/AD54.5		

金属软管接头(配金属波纹管)

Metal flexible tube connectors

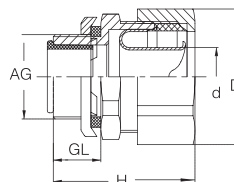

PG制 螺纹规格	配用软管 (d)	螺纹长度 (GL)	外圆直径 (D)	高度 (H)	公制规格	英制规格	订货号 Part Number
PG 9	10	8.5	26	30	WNC-PG9/D10	WNC-PG9/ 5/16"	
PG 11	12	10.5	27.5	32	WNC-PG11/D12	WNC-PG11/ 3/8"	
PG 13.5	15	11.5	31.5	34	WNC-PG13.5/D15		
PG 16	15	12.5	32	34	WNC-PG16/D15		
PG 21	20	13.5	38	37	WNC-PG21/D20	WNC-PG21/ 3/4"	
PG 29	25	15	45.5	44	WNC-PG29/D25	WNC-PG29/ 1"	
PG 29	32	14	55	52	WNC-PG29/D32	WNC-PG29/ 1-1/4"	
PG 36	38	17	62	51	WNC-PG36/D38		
PG 42	38	17	62	51	WNC-PG42/D38		
PG 48	51	19	77.5	56	WNC-PG48/D51		

M公制 螺纹规格	配用软管 (d)	螺纹长度 (GL)	外圆直径 (D)	高度 (H)	公制规格	英制规格	订货号 Part Number
M16X1.5	8	8	24	28	WNC-M16/D8	WNC-M16/ 5/16"	
M16X1.5	10	8	25.5	30	WNC-M16/D10	WNC-M16/ 5/16"	
M20X1.5	12	10	27.5	32	WNC-M20/D12	WNC-M20/ 3/8"	
M24x1.5	15	11.5	32	34	WNC-M24/D15		
M30x2.0	20	13	38	37	WNC-M30/D20	WNC-M30/ 3/4"	
M36x2.0	25	13	45	44	WNC-M36/D25	WNC-M36/ 1"	

附件产品系列 / Cable fittings and accessories



尼龙塑料扩径圈

适用于需要将螺纹直径扩大的情况下。

材料: 尼龙塑料

密封件: 丁腈橡胶

工作温度: -40℃~+100℃

Material: Ployimide

Seal material: NBR

Press seal material: PA

Temperature range: -40℃~+100℃

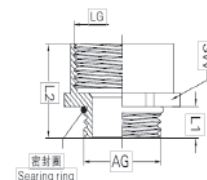

外螺纹 (AG)	内螺纹 (LG)	外螺纹长 (L1) mm	总长度 (L2) mm	扳手尺寸 (SW) (SW) mm	型号	订货号 Part Number
PG 制螺纹 PG Thread						
PG 7	PG9	8	20	19	WNSCP-PG7PG9	
PG 9	PG11	10	24	22	WNSCP-PG9PG11	
PG 11	PG13.5	8	23	24	WNSCP-PG11PG13.5	
PG 13.5	PG16	8	25	27	WNSCP-PG13.5PG16	
PG 16	PG21	10	27	30	WNSCP-PG16PG21	
PG 21	PG29	11	32	42	WNSCP-PG21PG29	
PG 29	PG36	11	35	52	WNSCP-PG29PG36	
PG 36	PG42	13	42	60	WNSCP-PG36PG42	
PG 42	PG48	15	65	65	WNSCP-PG42PG48	
M 公制螺纹 Metric Thread						
M12x1.5	M16x1.5	8	22	20	WNSCP-M12M16	
M16x1.5	M20x1.5	10	27	27	WNSCP-M16M20	
M20x1.5	M25x1.5	8	25	30	WNSCP-M20M25	
M25x1.5	M32x1.5	11	30	36	WNSCP-M25M32	
M32x1.5	M40x1.5	15	34	45	WNSCP-M32M40	
M40x1.5	M50x1.5	13	37	55	WNSCP-M40M50	

尼龙塑料减径圈

适用于需要将螺纹直径减小的情况下。

材料: 尼龙塑料

密封件: 丁腈橡胶

工作温度: -40℃~+100℃

Material: Ployimide

Seal material: NBR

Press seal material: PA

Temperature range: -40℃~+100℃

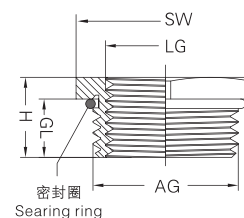

外螺纹 (AG)	内螺纹 (LG)	外螺纹长 (GL) mm	总长度 (H) mm	扳手尺寸 (SW) (SW)mm	型号	订货号 Part Number
PG 制螺纹 PG Thread						
PG 11	PG9	8	15	24	WNSCP-PG11PG9	
PG 13.5	PG11	9	21.5	22	WNSCP-PG13.5PG11	
PG 16	PG11	10	16	27	WNSCP-PG16PG11	
PG 16	PG13.5	10	17	27	WNSCP-PG16PG13.5	
PG 21	PG16	11	17	39	WNSCP-PG21PG16	
PG 29	PG21	11.5	17	39	WNSCP-PG29PG21	
M 公制螺纹 Metric Thread						
M20x1.5	M16x1.5	9.5	15	24	WNSCP-M20M16	
M25x1.5	M20x1.5	10	17	27	WNSCP-M25M20	
M32x1.5	M20x1.5	11.5	17	39	WNSCP-M32M20	
M32x1.5	M25x1.5	11	17	39	WNSCP-M32M25	
M40x1.5	M32x1.5	11	17	45	WNSCP-M40M32	

附件产品系列 / Cable fittings and accessories



金属扩径圈

适用于需要将螺纹直径扩大的情况下

材料: 黄铜镀镍 Material: Ployimide
 密封件: 丁腈橡胶 Seal material: NBR
 工作温度: $-40^{\circ}\text{C}\sim+100^{\circ}\text{C}$ Press seal material: PA
 Temperature range: $-40^{\circ}\text{C}\sim+100^{\circ}\text{C}$

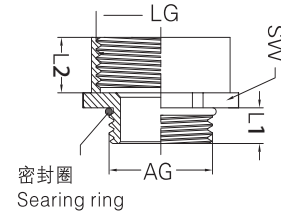

外螺纹 (AG)	内螺纹 (LG)	外螺纹长 (L1) mm	总长度 (L2) mm	扳手尺寸 (SW) (SW) mm	型号	订货号 Part Number
PG 制螺纹 PG Thread						
PG 7	PG9	5	8	17	WNSC-PG7PG9	
PG 9	PG11	6	10	20	WNSC-PG9PG11	
PG 11	PG13.5	6	10	22	WNSC-PG11PG13.5	
PG 13.5	PG16	6.5	11	24	WNSC-PG13.5PG16	
PG 16	PG21	6.5	12	30	WNSC-PG16PG21	
PG 21	PG29	8	13.5	40	WNSC-PG21PG29	
PG 29	PG36	8	15.5	50	WNSC-PG29PG36	
PG 36	PG42	9	14.5	57	WNSC-PG36PG42	
PG 42	PG48	10	14.5	65	WNSC-PG42PG48	
M 公制螺纹 Metric Thread						
M12x1.5	M16x1.5	5	8	18	WNSC-M12M16	
M16x1.5	M20x1.5	6	10	22	WNSC-M16M20	
M20x1.5	M25x1.5	8	13.5	27	WNSC-M20M25	
M25x1.5	M32x1.5	7.5	13.5	35	WNSC-M25M32	
M32x1.5	M40x1.5	10	13.5	45	WNSC-M32M40	
M40x1.5	M50x1.5	10	14.5	55	WNSC-M40M50	
M50x1.5	M63x1.5	9	14.5	65	WNSC-M50M63	

金属减径圈

适用于需要将螺纹直径减小的情况下

材料: 黄铜镀镍 Material: Ployimide
 密封件: 丁腈橡胶 Seal material: NBR
 工作温度: $-40^{\circ}\text{C}\sim+100^{\circ}\text{C}$ Press seal material: PA
 Temperature range: $-40^{\circ}\text{C}\sim+100^{\circ}\text{C}$

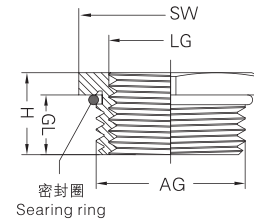

外螺纹 (AG)	内螺纹 (LG)	外螺纹长 (GL) mm	总长度 (H) mm	扳手尺寸 (SW) (SW)mm	型号	订货号 Part Number
PG 制螺纹 PG Thread						
PG 11	PG9	7	11	20	WNSC-PG11PG9	
PG 13.5	PG11	7	10	22	WNSC-PG13.5PG11	
PG 16	PG13.5	7	11	24	WNSC-PG16PG13.5	
PG 21	PG16	7	11	30	WNSC-PG21PG16	
PG 29	PG21	8	13	40	WNSC-PG29PG21	
PG 36	PG29	9	13	50	WNSC-PG36PG21	
PG 42	PG36	9	15	57	WNSC-PG 42PG36	
PG 48	PG42	10	15	65	WNSC-PG 48PG42	
M 公制螺纹 Metric Thread						
M20x1.5	M16x1.5	7	15	22	WNSC-M20M16	
M25x1.5	M20x1.5	7	17	27	WNSC-M25M20	
M32x1.5	M25x1.5	8	17	35	WNSC-M32M25	
M40x1.5	M32x1.5	9	17	42	WNSC-M40M32	
M50x1.5	M40x1.5	9	17	57	WNSC-M50M40	
M63x1.5	M50x1.5	9	17	57	WNSC-M63M50	

附件产品系列 / Cable fittings and accessories



尼龙塑料电缆接头, IP68
Cable gland, IP68, nylon sealing insert



材料: 尼龙塑料
密封件: 丁腈橡胶
夹紧件: 尼龙塑料
工作温度: -40°C~+100°C
防护等级: IP68

Material: Ploymide
Seal material: NBR
Press seal material: PA
Temperature range: -40°C~+100°C
Protection degree: IP68

PG制螺纹规格	电缆直径 mm	螺纹长度 mm	本体高度 mm	板手直径 mm	螺纹外径 mm	订货号 Part Number
PG 7	2-5/3-6.5	8	22	16	12.5	
PG 9	2-6/4-8	8	26	19	15.2	
PG 11	3-7/5-10	8	27	22	18.6	
PG 13.5	5-9/6-12	9	28	24	20.4	
PG 16	7-12/10-14	10	30	27	22.5	
PG 21	9-16/13-18	10	35	33	28.3	
PG 29	13-20/18-25	12	40	41/42	37	
PG 36	20-26/23-32	14	48	52/53	47	
PG 42	25-31/32-38	14	49	60/61	54	
PG 48	29-35/37-44	14	50	64/65	59.3	
PG 63	42-50	27	60	72	70	

M公制螺纹规格	电缆直径 mm	螺纹长度 mm	本体高度 mm	板手直径 mm	螺纹外径 mm	订货号 Part Number
M12X1.5	3-6.5	8	22	16	12	
M16X1.5	4-8	8	26	19	16	
M20X1.5	6-12	9	28	24	20	
M25X1.5	13-18	10	35	33	25	
M32X1.5	16-21	11	34	36-37	32	
M32X1.5	18-25	12	40	42	32	
M40X1.5	22-32	14	48	52-53	40	
M50X1.5	32-38	14	49	60/61	50	
M63X1.5	37-44	14	50	67	63	

金属电缆接头, 黄铜镀镍, IP68
Cable glands, IP68, brass nicked-plated, nylon sealing insert



材料: 黄铜镀镍
密封件: 丁腈橡胶
夹紧件: 尼龙塑料
工作温度: -40°C~+100°C
防护等级: IP68

Material: Nicked plated brass
Seal material: NBR
Press seal material: PA
Temperature range: -40°C~+100°C
Protection degree: IP68

PG制螺纹规格	电缆直径 mm	螺纹长度 GL mm	本体高度 H mm	板手直径 mm	螺纹外径 AG mm	订货号 Part Number
PG 7	2-5/3-6.5	5	18	14	12.5	
PG 9	2-6/4-8	6	20	17	15.2	
PG 11	3-7/5-10	6	21	20	18.6	
PG 13.5	5-9/6-12	6.5	22	22	20.4	
PG 16	7-12/10-14	6.5	23	24	22.5	
PG 21	9-16/13-18	7	25	30	28.3	
PG 29	13-20/18-25	8	30	40	37	
PG 36	20-26/23-32	8	35	50	47	
PG 42	25-31/32-38	9	38	57	54	
PG 48	29-35/37-44	10	40	64	59.3	

M公制螺纹规格	电缆直径 mm	螺纹长度 GL mm	本体高度 H mm	板手直径 mm	螺纹外径 AG mm	订货号 Part Number
M12X1.5	3-6.5	5	18	14	12	
M16X1.5	4-8	6	20	17	16	
M20X1.5	6-12	6.5	22	22	20	
M25X1.5	13-18	7	25	30	25	
M32X1.5	18-25	8	30	40	32	
M40X1.5	22-32	8	35	50	40	
M50X1.5	32-38	9	38	57	50	
M63X1.5	37-44	10	40	64/68	64	

底部外壳安装所需开孔尺寸/Housing mounting dimensions

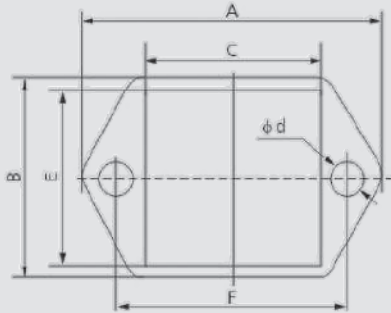

G3A开孔底座
G3A series housings

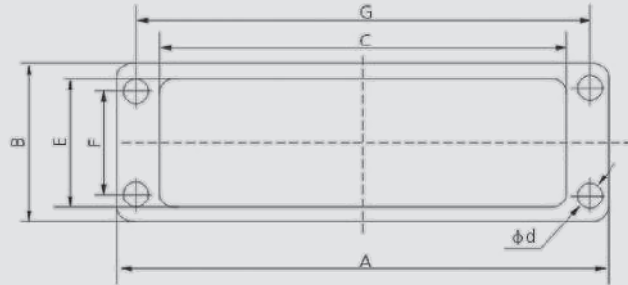

G10A, G16A, G32A开孔底座
G6B, G10B, G16B, G24B, G32B, G48B开孔底座
G10A, G16A, G32A series housings
G6B, G10B, G16B, G24B, G32B, G48Bseries housings

插座外壳型号 Housing type	安装形式 Mounting type	尺寸/dimensions(mm)						
		A	B	C	E	F	G	ϕd
G3A	开孔安装/bulkhead	40	28	22	22	30	--	3.3
	表面安装/surface	39.5	39.5	--	--	30	--	3.3
G10A	开孔安装/bulkhead	81	30.5	58.5	24.5	18	70	3.5
	表面安装/surface	75	50	--	--	40	48	4.5
G16A	开孔安装/bulkhead	96.5	30.5	74.5	25	17.5	86	3.5
	表面安装/surface	95	50	--	--	40	64	4.5
G32A	开孔安装/bulkhead	101.5	56.5	74	49	42	92	4.5
	表面安装/surface	106	56.5	--	--	46	94	5.5
G6B	开孔安装/bulkhead	80	43.5	53	36	32	70	4.5
	表面安装/surface	82	52	--	--	40	70	5.5
G10B	开孔安装/bulkhead	92	43	66	36	32	83	4.5
	表面安装/surface	94	52	--	--	40	82	5.5
G16B	开孔安装/bulkhead	113	44	86	36	32	103	4.5
	表面安装/surface	117	56.5	--	--	45	105	5.5
G24B	开孔安装/bulkhead	139	44	113	36	32	130	4.5
	表面安装/surface	143.5	56.5	--	--	45	132	5.5
G32B	开孔安装/bulkhead	125	83.5	88	76	65	110	5.5
	表面安装/surface	124.5	81	--	--	67	112	5.5
G48B	开孔安装/bulkhead	166.2	96.5	117	81	70	148	6.5
	表面安装/surface	141.5	120	--	--	106	111	6.5